

EFFECT OF A MAGNETIC FIELD ON THE THROUGH-FLOW POTENTIAL  
IN MOVING AQUEOUS SYSTEMS

I. M. Ametov and R. V. Mustafin

UDC 622.276.344

The through-flow potential arising during the flow of water or aqueous solutions of surfactants characterized by different concentrations is investigated. It is shown that the flow potential can be regulated by applying a permanent, transverse magnetic field to the liquid in question at different flow velocities. It has been established that synergism manifests itself within a certain range of conditions, and the combined action of surfactant additions and the magnetic field tends to reduce the through-flow potential.

There is an ever-increasing number of papers devoted to the effect of a magnetic field on the characteristics of aqueous solutions and other liquids. A survey of these papers was provided in [1] after a certain body of work had accumulated. An approach to naturally occurring waters as complex, open, and nonstationary multiphase systems is described in monograph [2] within the framework of electromagnetic hydrophysics. It also provides theoretical considerations and estimates of the electromagnetic phenomena in naturally occurring waters. A possible mechanism whereby a magnetic field influences the activation of water is considered in [3]. The effect of a magnetic field on the characteristics of hydrocarbon liquids has been investigated in several papers. The variation of the rheological characteristics of non-Newtonian petroleum under the action of a transverse, alternating magnetic field has been studied in [4]. Experimental data on the effect of magnetic action on the liquid-gas phase transition are given in [5]. Similar data for gas-liquid systems are presented in [6]. Experimental investigations have shown that magnetically treated water augments the permeability of clays of the montmorillonite group [7]. Experiments under industrial conditions have shown that this phenomenon can be successfully used to improve the efficiency of oil production [8]. The effect of a magnetic field on the through-flow potential may be the cause of increase of water mobility in clays, i.e., in microcapillaries with dimensions of the order of  $10^{-5}$ - $10^{-6}$  m. We provide here the results of experimental investigations of the effect of a permanent, transverse magnetic field on the through-flow potential in water flow through a capillary and of the possibility of regulating this effect by means of various additives.

The effect of the through-flow potential on the flow characteristics obviously increases with a reduction in the capillary size. Therefore, the results obtained can be considered as an estimate "from below" for a porous medium.

The experiments were performed by means of an experimental arrangement comprising a glass tube with electrodes, a magnetizing device, an instrument for recording the through-flow potential, a signal amplifier, a piezometric tube, a vessel for the liquid under investigation, a compressed-nitrogen tank with reducing valves, a system of pipes with cock valves, and a screening casing.

The glass tube, which has an inside diameter of  $5 \cdot 10^{-3}$  m and a length of 1.2 m, has at its ends lead-outs for mounting the electrodes and lead-outs for connection to the piezometric tube. The distance between the electrodes is equal to 0.84 m.

The electrodes are made of silver wire with a diameter of  $0.75 \cdot 10^{-3}$  m. The electrode surface in contact with the liquid is located at the same level as the inside surface of the tube. The magnetizing device consists of a cylindrical iron frame with permanent magnets arranged inside. The magnetic field strength in the operating gap is equal to  $1.76 \cdot 10^5$  A/m  $\pm$  10%, while the total magnetic flux is equal to  $2.7$ - $3.0 \cdot 10^{-3}$  Wb.

The flow-through potential is recorded by means of a V7-27A/1 universal digital voltmeter. The maximum allowable basic error of the voltmeter in measuring the potential during experi-

---

A. P. Krylov All-Union Oil and Gas Scientific Research Institute, Moscow. Translated from *Inzhenerno-Fizicheskii Zhurnal*, Vol. 62, No. 3, pp. 391-395, March, 1992. Original article submitted May 14, 1991.

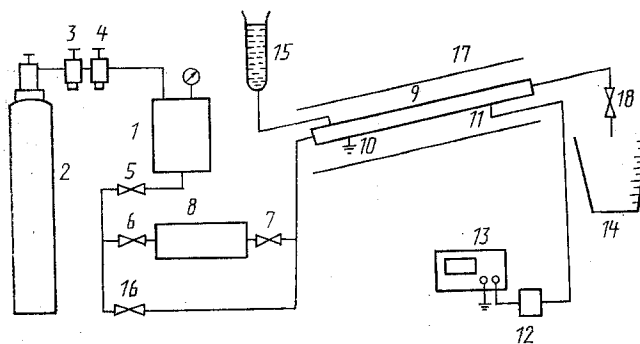

Fig. 1. Block diagram of the experimental arrangement.

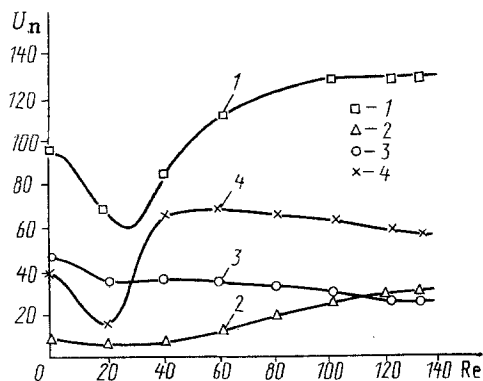

Fig. 2. Through-flow potential of nonmagnetized liquids as a function of the Reynolds number. 1) Water; 2) 0.15% solution of surfactant; 3) 0.3%; 4) 0.5%. The value of  $U_n$  is given in millivolts; the Re number is dimensionless.

ments is equal to  $\pm 0.35\%$ . Stability of voltmeter readings and noise reduction are achieved by using the signal amplifier and the screening casing. The amplifier is based on a UD-1408 working amplifier; the gain is equal to 10. The glass tube is placed in a metal jacket in order to screen out external noise. The jacket is made of galvanized sheet metal in the form of a tube with a length of 1.4 m and a diameter of 0.22 m. The glass tube and the screening jacket are positioned at an angle in order to prevent the accumulation of air bubbles in the tube. The pressure drop in the tube is determined with respect to the liquid level in the piezometric tube.

The vessel containing the liquid under investigation consists of a metal container with a pressure gauge, where constant pressure is maintained. The pressure is created by compressed nitrogen from the tank, which passes through two air pressure reducing valves for rough and fine pressure settings.

The liquid discharge is varied or kept constant by manipulating needle valves. The container, the magnetic device, and the glass tube are fastened by means of rubber tubing.

The block diagram of the experimental arrangement is shown in Fig. 1. The experimental method consists in the following. The liquid under investigation is poured into container 1. Pressure is created in container 1 from tank 2 through reducing valves 3 and 4. The liquid is supplied through the magnetic device 8 to the glass tube 9 by opening valves 5, 6, 7 and 18. The developing potential is supplied to amplifier 12 through electrodes 10 and 11 and is measured by means of a digital voltmeter, 13. The amount of liquid flowing through tube 9 is determined by means of the measuring vessel 14. The pressure at the inlet to the glass tube is measured with respect to the liquid level change in the piezometric tube 15. The liquid flows by gravity into the measuring vessel. When valves 5, 16, and 18 are opened, the liquid

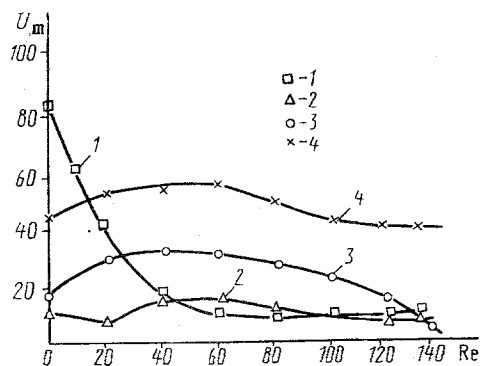

Fig. 3. Through-flow potential of magnetically treated liquid as a function of the Reynolds number; the notation is the same as in Fig. 2;  $U_m$  is given in millivolts.

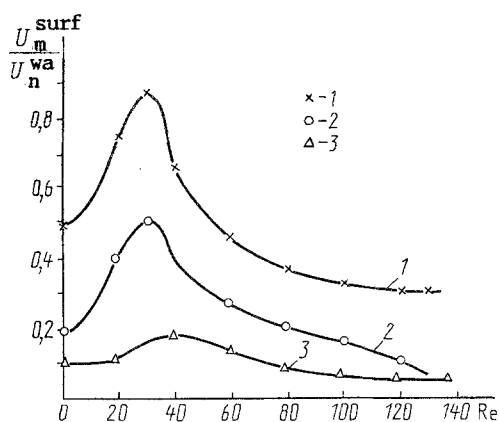

Fig. 4. Ratio of the through-flow potential of magnetically treated solutions to the potential of water not exposed to magnetization. 1) Potential ratio of a 0.5% solution; 2) 0.3%; 3) 0.15%. The values of  $U_m^{surf}$  and  $U_n^{wa}$  are given in millivolts.

enters the glass tube without being subjected to magnetization. The glass tube is located inside the screening jacket 17.

The experiments were performed by using tap water and solutions of ML-72 preparation in this water in concentrations of 0.15, 0.3, and 0.5% by volume. The ML-72 preparation consists of synthetic surfactants, the composition of which comprises decomposable biochemical anions and nonionogenic surfactants. It has a liquid consistency of medium viscosity, a dark brown color, and a weak specific odor; it is readily soluble in fresh, sea, and deposit waters. The pH value of a 1%-solution of the preparation in distilled water is equal to 7-9. Observations during experiments have shown that the time of establishment of a constant through-flow potential in a moving liquid depends on the flow velocity. With an increase in the flow velocity, less time is necessary for stabilization of the potential of all the liquids investigated, with the exception of magnetically treated water, for which this time increases with the flow velocity. In each experiment, the time at which the through-flow potential starts to stabilize coincided with the time necessary for replacing the volume of nonmagnetized liquid by the magnetized liquid, or vice versa. The time during which the liquid is located in the magnetic field depends on the flow velocity set in each individual experiment. For instance, for the flow velocity in the glass tube corresponding to the number  $Re = 25$ , the time during which the liquid is located within the operating-strength magnetic field is equal to 150 sec.

For all the liquids investigated, the through-flow potential diminishes for flow velocities corresponding to Re numbers from 0 to 20-25 (Fig. 2). Beyond that, at high flow velocities, the through-flow potential increases for all liquids. For water and a 0.15% solution of ML-72, the potential increases within the velocity range investigated. For solutions with concentrations of 0.3 and 0.5%, the potential rises up to  $Re = 50$ . For large values of Re, the flow-through potential of these solutions decreases. Figure 3 shows the results of experiments on determining the through-flow potential for liquids treated in a magnetic field as a function of the Reynolds number. Experiments show that the through-flow potential for tap water drops sharply with an increase in the flow velocity. The drop occurs up to  $Re = 70$ , while the potential is constant at high velocities in the Re range investigated. Of all the liquids investigated that have been exposed to magnetic treatment, the lowest value of the through-flow potential occurs for a 0.15% solution of surfactant, with the exception of the  $Re = 45-95$  range, where the potential is lower for water. The through-flow potential rises with an increase in the surfactant concentration.

An analysis of a series of experiments on magnetically treated solutions for which the through-flow potential is at a minimum. This line of investigation should be pursued further.

Figure 4 illustrates the reduction of the through-flow potential of magnetically treated surfactant solutions in comparison with the potential for water not exposed to magnetization. Throughout the velocity range in question, the through-flow potential of surfactant solutions exposed to magnetization was lower than that of water not exposed to magnetization. With an increase in the surfactant concentration, the potential reduction is smaller for the corresponding Re numbers.

Analysis of the experimental results indicates that the synergetic effect of combined action of the magnetic field and the surfactant addition on the through-flow potential manifests itself under certain conditions (surfactant concentration, flow velocity). Thus, for instance, exposure of water to magnetization reduces the through-flow potential at  $Re = 5$  by 17% (curves 1 in Figs. 2 and 3). An addition of 0.3% surfactant to water reduces the potential at  $Re = 5$  by 52% (curves 1 and 3 in Fig. 2).

Thus, the total possible potential reduction would amount to 69%. However, the actual potential reduction for a surfactant solution of 0.3% that has been magnetically treated at  $Re = 5$  in relation to the potential of water not exposed to magnetization amounts to 80% (curve 2 in Fig. 4). Analysis of the experimental results indicates that the synergetic effect manifests itself for small Re numbers and low surfactant concentrations. Extrapolation of the pertinent curves in the diagrams indicates that the synergy effect manifests itself up to  $Re = 8$ .

Our experimental investigations have shown that magnetic treatment of water and aqueous solutions of surfactants reduces the through-flow potential. The nature of changes in the through-flow potential of magnetically treated liquids and those not so treated has been revealed in relation to the Reynolds number. It has been found that a synergetic effect of the combined action of surfactant additions to water and of the magnetic field on the reduction of the through-flow potential manifests itself in a certain range of conditions.

#### NOTATION

Re, Reynolds number; U, potential. Subscripts: n, not magnetically treated; m, magnetically treated; wa, water.

#### LITERATURE CITED

1. V. I. Klassen, Magnetic Treatment of Water Systems [in Russian], Moscow (1978).
2. N. F. Bondarenko and E. Z. Gak, Electromagnetic Phenomena in Naturally Occurring Waters [in Russian], Leningrad (1984).
3. M. I. Davidzon, *Uzv. Vyssh. Uchebn. Zaved., Fiz.*, No. 4, 89-94 (1985).
4. F. G. Veliev, *Magn. Gidrodin.*, No. 1, 139-143 (1979).
5. G. G. Vakhitov, V. P. Maksimov, R. T. Bulgakov, et al., Mining in Deposits where the Face Pressure is Lower than the Saturation Pressure [in Russian], Moscow (1982).
6. A. Kh. Mirzadzhanzade, I. M. Ametov, K. S. Basniev, et al., Technology of Natural Gas Production [in Russian], Moscow (1987).
7. A. M. Mamed-Zade, T. Sh. Salavatov, and L. R. Éidel'man, "Non-equilibrium effects and nonlinear waves in oil and gas production," in: Subjects in the Collection of Scientific

Papers (Trudy) of the M. Azizbekov AzINEFTEKhIM (Azerbaijani Petroleum Chemical Institute) [in Russian], Baku (1984), pp. 60-63.

8. A. Kh. Mirzadzhanzade, F. G. Magsudov, R. I. Nigmatullin, et al., Theory and Practice of Utilizing Nonequilibrium Systems in Oil and Gas Production [in Russian], Baku (1985).